

ADVANTAGE FACTORY AIR

INSTALLATION INSTRUCTIONS FOR

1967 CHEVELLE

WITH FACTORY AIR CONDITIONING

(56467-ACZ-A)

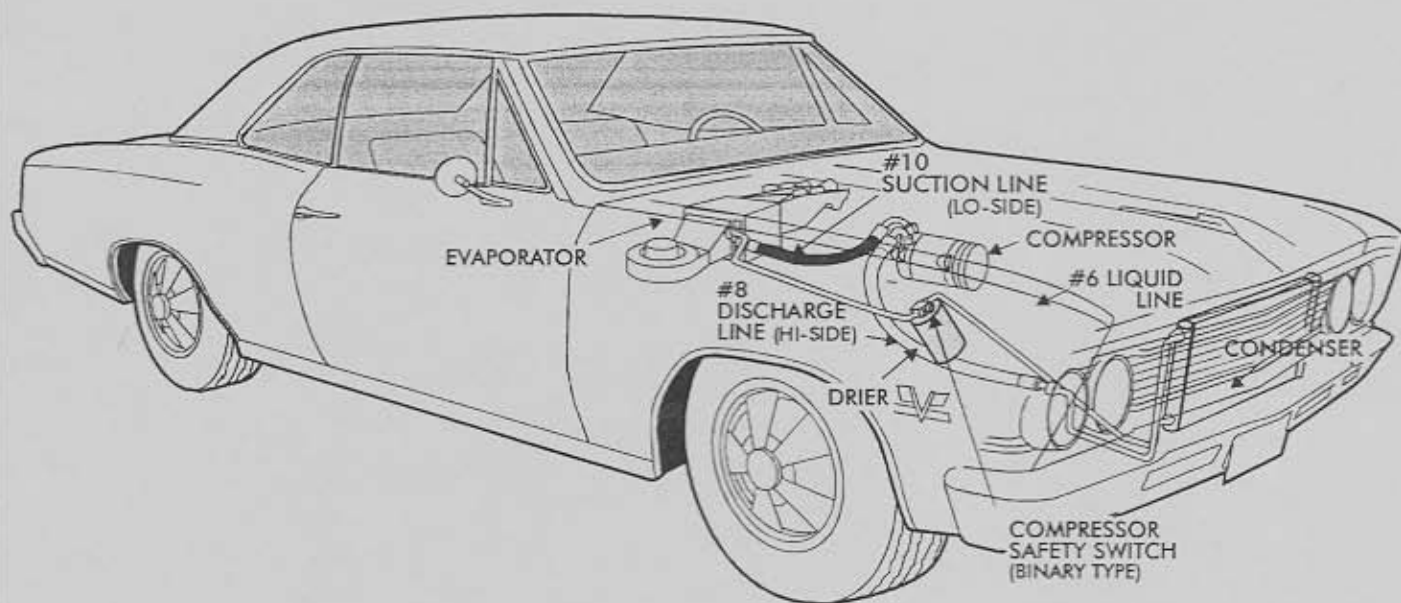

10305 I.H. 35 N. - SAN ANTONIO, TX. - 78233 - ph.210-654-7171 - fax 210-654-3113

1967 CHEVELLE

WITH FACTORY AIR CONDITIONING

IMPORTANT NOTICE-PLEASE READ

**FOR MAXIMUM SYSTEM PERFORMANCE
VINTAGE AIR RECOMMENDS THE FOLLOWING:**

RADIATOR - 70071-VCR
SHROUD - 32071-VCF
FAN - 32518-VUF
FAN CLUTCH - 32000-VUF

SAFETY SWITCHES:

YOUR NEW VINTAGE AIR SYSTEM INCLUDES A BINARY COMPRESSOR SAFETY SWITCH. A BINARY SWITCH (PART # 24677-VUS) DISENGAGES THE COMPRESSOR CLUTCH IN CASE OF EXTREME LOW PRESSURE CONDITION (REFRIGERANT LOSS) OR EXCESSIVELY HIGH HEAD PRESSURE (380 lb.), TO PREVENT COMPRESSOR DAMAGE OR HOSE RUPTURE. A TRINARY SWITCH (V.A. PART# 24678) COMBINES HI/LO PRESSURE PROTECTION WITH AN ELECTRIC FAN OPERATION SIGNAL AT 220 lbs. COMPRESSOR SAFETY SWITCHES ARE EXTREMELY IMPORTANT SINCE AN A/C SYSTEM RELIES ON REFRIGERANT TO CARRY LUBRICATION THROUGH THE SYSTEM.

SERVICE INFO:

EVACUATE THE SYSTEM FOR 35-45 MINUTES WITH SYSTEM COMPONENTS (DRIER, COMPRESSOR, EVAPORATOR AND CONDENSER) AT A TEMPERATURE OF AT LEAST 85° F. ON A COOL DAY THE COMPONENTS CAN BE HEATED WITH A HEAT GUN OR BY RUNNING THE ENGINE WITH THE HEATER ON BEFORE EVACUATING. LEAK CHECK AND CHARGE TO SPECIFICATIONS.

THE PROPER AMOUNT OF REFRIGERANT IS CRITICAL TO PROPER SYSTEM OPERATION. VINTAGE AIR RECOMMENDS OUR SYSTEMS BE CHARGED BY WEIGHT WITH A QUALITY CHARGING STATION OR SCALE.

REFRIGERANT CAPACITIES

134a SYSTEM

CHARGE WITH 1.8 LBS. OF REFRIGERANT

R-12 SYSTEM

CHARGE WITH 2.0 LBS. OF REFRIGERANT

LUBRICANT CAPACITIES

**NEW COMPRESSOR - NO ADDITIONAL OIL NEEDED
USED COMPRESSOR - CONSULT VINTAGE AIR**

INSTALLATION INSTRUCTIONS



BEFORE STARTING THE AIR CONDITIONING INSTALLATION, CHECK FOR PROPER OPERATION OF ALL COMPONENTS (RADIO, LIGHTS, WIPERS, ETC.). STUDY THE INSTRUCTIONS, ILLUSTRATIONS AND DIAGRAMS. FOR EASE OF INSTALLATION CHECK OFF (✓) EACH PROCEDURE PRIOR TO MOVING ON TO NEXT STEP.

ENGINE COMPARTMENT (SEE FIGURE 1)

- DISCONNECT AND REMOVE BATTERY AND TRAY.
- DRAIN RADIATOR.
- JACK UP VEHICLE AND SUPPORT WITH JACK STANDS.
- REMOVE HOOD LATCH ASSEMBLY (RETAIN).
- REMOVE GRILLE BRACE (RETAIN).
- REMOVE PASSENGER SIDE FRONT WHEEL (RETAIN).
- DISCONNECT PARKING LIGHT ELECTRICAL CONNECTION (UNDER BATTERY BOX).
PUSH GROMMET DOWN OUT OF INNER FENDER PANEL AND SECURE WIRES INSIDE BUMPER.
- DISCONNECT HEATER HOSES FROM HEATER AND SECURE HOSES TO ENGINE.
- ANY OTHER ACCESSORIES ATTACHED TO INNER FENDER PANEL MUST BE REMOVED AT THIS TIME.
- REMOVE INNER FENDER PANEL.
- REMOVE BLOWER MOTOR WIRING (DISCARD).
- REMOVE ORIGINAL EVAPORATOR & BLOWER HOUSING (DISCARD). RETAIN O.E.M EVAP./BLOWER MOUNTING HARDWARE FOR INSTALLATION OF FIREWALL COVERS.
- CLEAN FIREWALL OF ALL O.E.M SEALER.

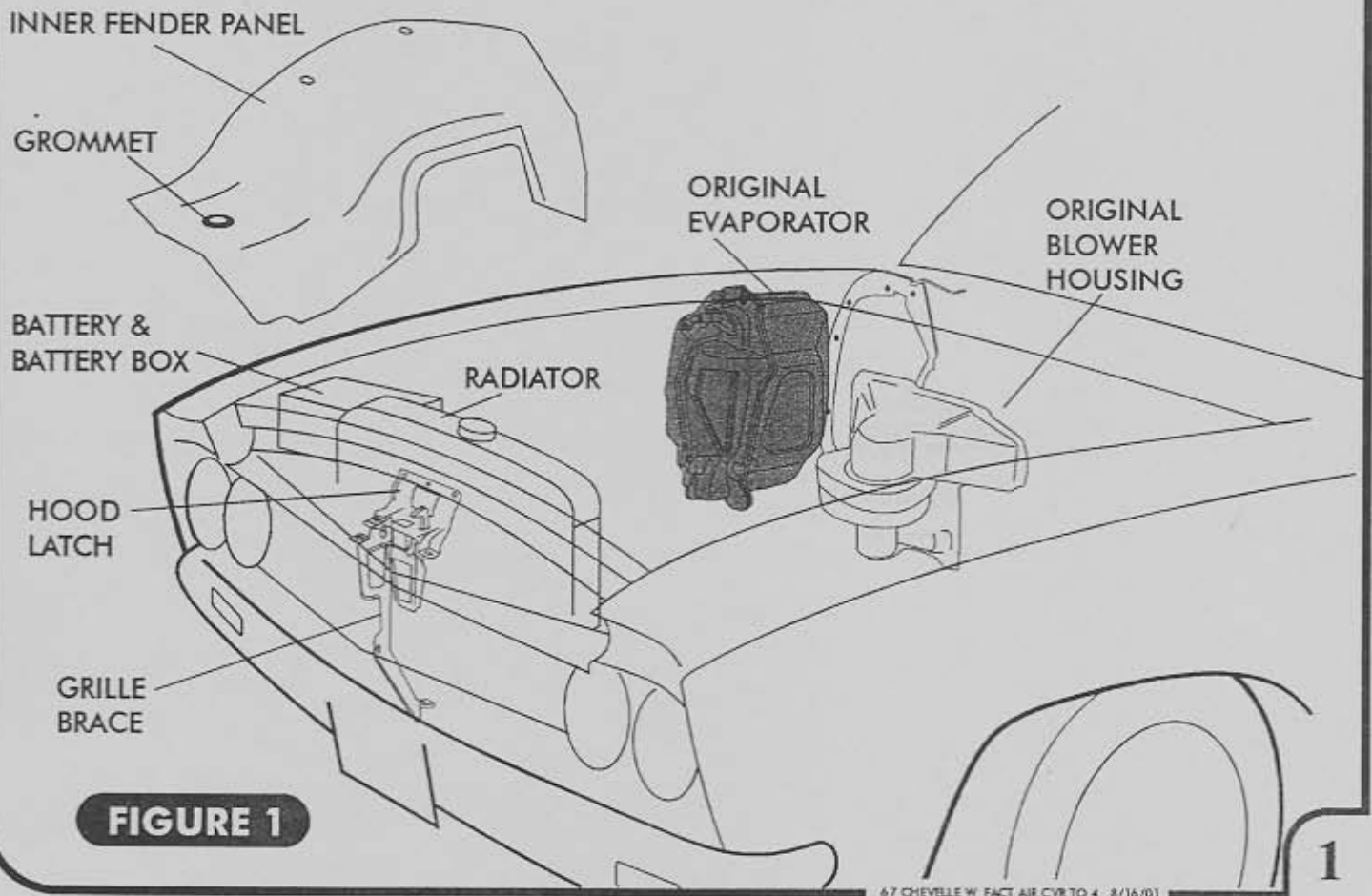

FIGURE 1

PASSENGER COMPARTMENT (SEE FIGURE 2)

- 1. REMOVE FRONT SEATS. (OPTIONAL)
- 2. DISCONNECT LIGHT FOR GLOVE BOX DOOR IF EQUIPPED.
- 3. REMOVE GLOVE BOX DOOR (RETAIN) AND GLOVE BOX (DISCARD).



THERE MAY STILL BE A SMALL AMOUNT OF WATER LEFT IN HEATER CORE AND HOSES. PLUG HEATER CORE OUTLETS BEFORE REMOVING FROM VEHICLE.

- 4. REMOVE THE CABLES FROM THE A/C AND HEATER PLENUMS (DISCARD).
- 5. REMOVE O.E.M HEATER BOX.
- 6. REMOVE DEFROST DUCTS (DISCARD DUCTS, RETAIN HARDWARE).
- 7. REMOVE CONTROL PANEL (RETAIN).
- 8. REMOVE RADIO (RETAIN).
- 9. REMOVE PASSENGER SIDE KICK PANEL.
- 10. REMOVE FRESH AIR VALVE ASSEMBLY FROM WITHIN KICK PANEL.

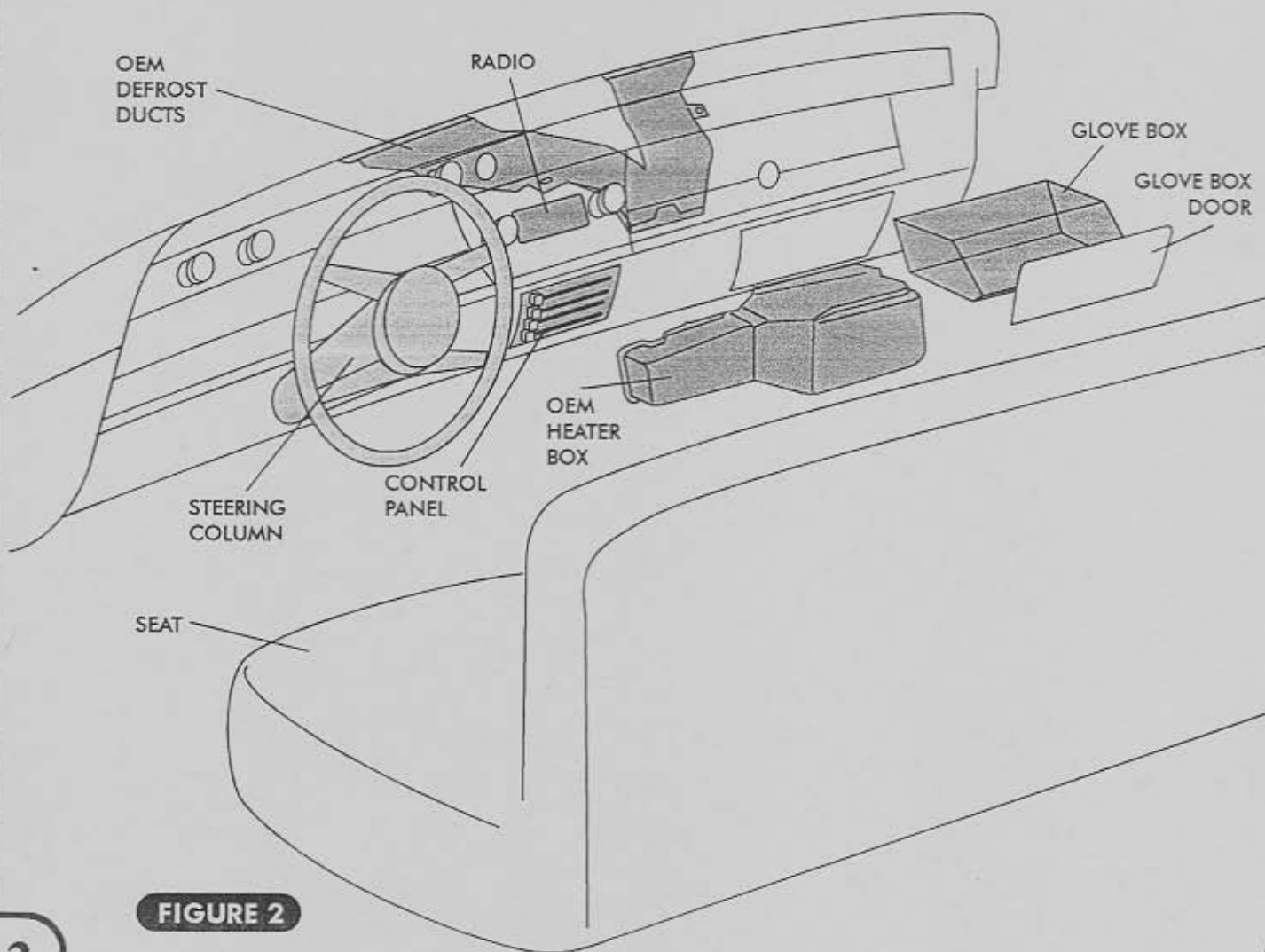
FIGURE 2

ASSEMBLY - ENGINE COMPARTMENT

COMPRESSOR AND BRACKETS

- REFER TO SEPARATE INSTRUCTIONS TO INSTALL COMPRESSOR BRACKET USING HARDWARE INCLUDED WITH THE BRACKET.
- INSTALL COMPRESSOR USING TABS "C" AND "G" AS PIVOT POINTS. SEE FIGURE 3.

BELTS AND PULLEYS (SEE FIGURE 3)

SMALL BLOCK CHEVY: A/C BELT ROUTES AROUND THE BACK GROOVE ON WATER PUMP. ALT. BELT ROUTES AROUND THE FRONT GROOVE ON WATER PUMP.

PULLEY REQUIREMENTS-

DOUBLE GROOVE WATER PUMP PULLEY
 DOUBLE GROOVE CRANK PULLEY
 IF EQUIPPED WITH POWER STEERING PUMP,
 A THREE GROOVE CRANK PULLEY IS REQUIRED.
 A DOUBLE GROOVE ALTERNATOR PULLEY MAY
 BE REQUIRED.

NOTE: GM PULLEYS AVAILABLE SEPARATELY FROM VINTAGE AIR

BIG BLOCK CHEVY: A/C BELT ROUTES AROUND THE FRONT GROOVE ON WATER PUMP. ALT. BELT ROUTES AROUND THE BACK GROOVE ON WATER PUMP.

PULLEY REQUIREMENTS-

DOUBLE GROOVE WATER PUMP PULLEY
 DOUBLE GROOVE CRANK PULLEY
 IF EQUIPPED WITH POWER STEERING PUMP,
 A THREE GROOVE CRANK PULLEY IS REQUIRED.

CONDENSER ASSEMBLY

NOTE → LOOSENING CONDENSER BRACKET SCREWS 1/4 TURN WILL EASE BRACKET TO RADIATOR CORE SUPPORT ALIGNMENT AND AID IN LEVELING OF CONDENSER. ONCE CONDENSER IS INSTALLED AND LEVELED, RE- TIGHTEN ALL CONDENSER BRACKET SCREWS.

- ATTACH CONDENSER TO THE FRONT SIDE OF RADIATOR SUPPORT BY USING THE PROTRUDING RADIATOR ATTACHING BOLTS AS STUDS AND FASTEN WITH THE TWO (2) 5/16" NUTS (SUPPLIED). (SEE FIGURE 7, PAGE 5). IF BOLTS ARE NOT LONG ENOUGH, REPLACE WITH BOLTS AT LEAST 1" LONG.
- THE TOP BRACKETS GO BETWEEN THE CORE SUPPORT AND THE HOOD LATCH ASSEMBLY (SEE FIGURE 6, PAGE 5).
- REINSTALL GRILL BRACE (USING SMALL BOLT AND LOCK NUT IN PLACE OF RIVETS. -OPTIONAL)

NOTE → SLIGHT SEPARATION OF THE TWO RIVET TAB EXTENSIONS WILL EASE RE-INSTALLATION OF GRILL BRACE. DROP BRACE IN WITH EXTENSION POINTING TOWARDS THE DRIVER SIDE THEN TURN CLOCKWISE INTO POSITION.

- REINSTALL THE HOOD LATCH ASSEMBLY USING O.E.M. BOLTS.

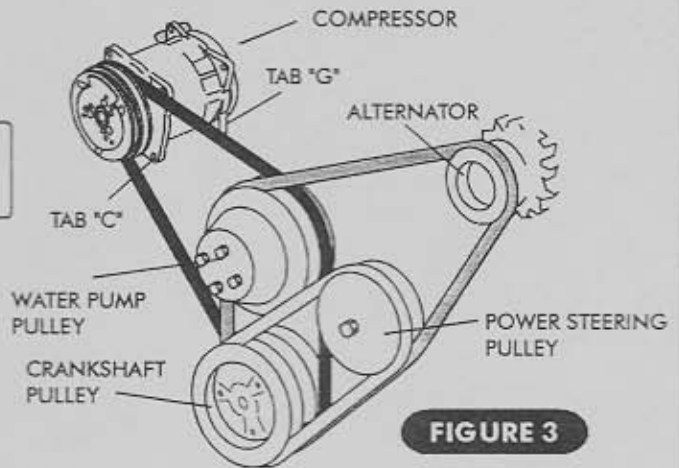

FIGURE 3

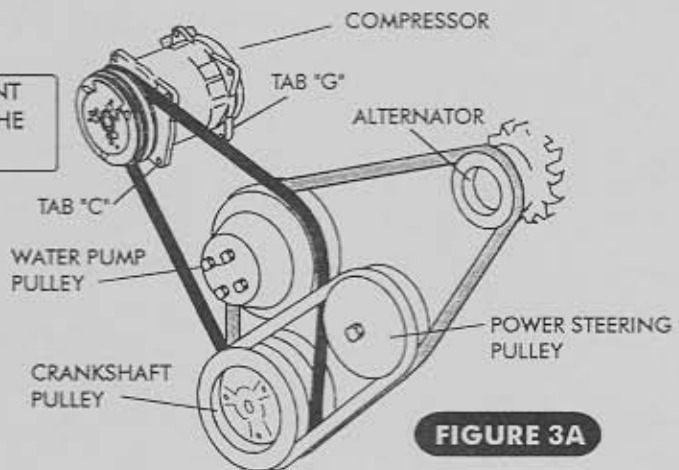

FIGURE 3A

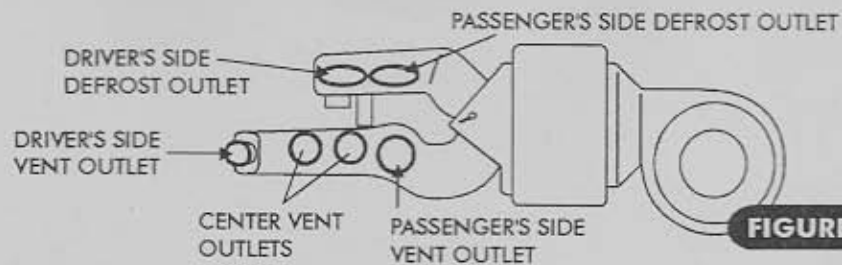

FIGURE 11

FIREWALL COVER INSTALLATION (SEE FIGURE 12)

- REMOVE ALL FIREWALL INSULATION PAD RETAINING GROMMETS TO THE RIGHT OF O.E.M HEATER COIL EXIT HOLES AND USE SILICONE TO SECURE PAD TO FIREWALL.
- APPLY A BEAD OF SEALER (1/4" TALL) AROUND THE INSIDE EDGE OF FIREWALL COVER AND INSTALL ON THE OUTSIDE OF THE FIREWALL USING FOUR (4) 1/4" x 1" BOLTS, WASHERS AND NUTS, PLACING ONE WASHER ON EACH SIDE OF FIREWALL AT HOLE LOCATIONS #2 THRU #5 ON FIRE WALL COVER. (SEE FIGURE 12 BELOW)

NOTE DO NOT INSTALL THE # 1, 1/4" x 1" BOLT BUT MAKE SURE THE HOLE IS UNOBSTRUCTED. THIS BOLT WILL HOLD THE EVAPORATOR TO THE FIREWALL. NOTE: DO NOT OVER TIGHTEN BOLTS.

FRESH-AIR / EVAPORATOR COVERS:

- ALIGN FRESH AIR BLOCK OFF PLATE WITH THE FACTORY STAMPED HOLE ON FIREWALL AND LEVEL WITH THE TOP OF THE COWL (SEE FIGURE 12 BELOW). TEMPORARILY INSTALL 1/4"-20X1" BOLT IN ALIGNMENT HOLE.
- FROM INSIDE THE CAR, MARK HOLE "C" ON FRESH AIR BLOCK-OFF PLATE. FROM OUTSIDE ON THE FIREWALL MEASURE AND MARK HOLES "A" AND "B". REMOVE PLATE AND DRILL HOLES TO 5/16".
- REMOVE FRESH AIR BLOCK PLATE. APPLY A 1/4" BEAD OF SEALER AND REINSTALL COVER USING O.E.M FASTENERS AND 1/4"-20X1" BOLT, WASHER, AND HEX NUT.
- ALIGN EVAPORATOR BLOCK OFF PLATE IN POSITION AND DUCT TAPE ON TO FIREWALL. MAKE SURE TAPING SURFACE IS CLEAN SO TAPE ADHERES PROPERLY.
- FROM INSIDE THE CAR, THROUGH KICK PANEL OPENING, MARK TWO OPPOSING HOLE LOCATIONS.
- REMOVE EVAP. BLOCK OFF PLATE, DRILL THE TWO MARKED HOLE LOCATIONS AND RE-MOUNT USING O.E.M. FASTENERS.
- REPEAT PROCESS UNTIL ALL HOLES ARE DRILLED IN EVAP. BLOCK OFF PLATE.
- ONCE ALL HOLES ARE DRILLED AND LINE UP PROPERLY, APPLY 1/4" OF SEALER AND MOUNT THE PLATE WITH O.E.M. FASTENERS.
- INSTALL EVAPORATOR KICK PANEL BLOCK-OFF PLATE WITH O.E.M. FASTENERS
- REINSTALL INNER FENDER.

FIGURE 12

NOTE: "X" INDICATES 5/16" HOLES THAT NEED TO BE DRILLED BY INSTALLER.

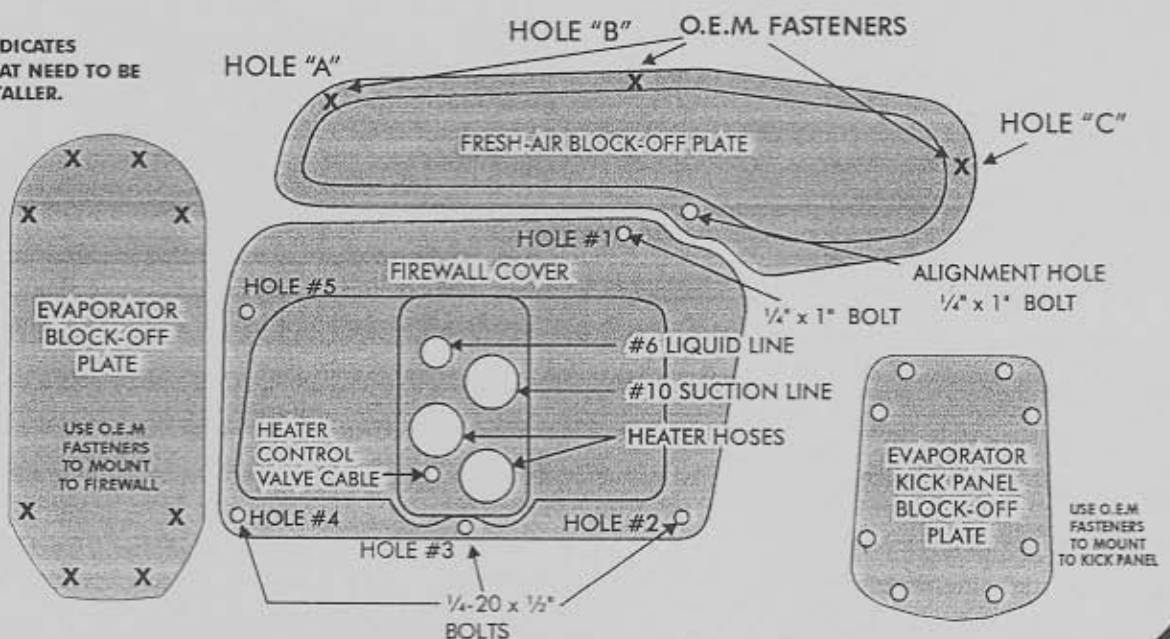

CONDENSER HARD LINE INSTALL

- LOCATE THE O-RING PACKAGE. THERE IS A SPECIFIC SIZE AND THICKNESS O-RING FOR EACH CONNECTION. THE SMALL WHITE TUBE IS A SPECIFIC OIL FOR O-RINGS AND THREADS. (SEE FIGURE 4). O-RINGS SHOULD NOT BE REUSED ONCE A FITTING IS TIGHTENED (DISCARD AND INSTALL NEW O-RINGS). DO NOT OVER TIGHTEN. ALWAYS USE TWO (2) WRENCHES TO PREVENT TWISTING FITTINGS ON HARDLINE (SEE FIGURE 5).

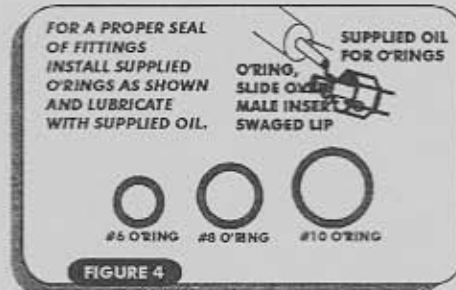

- LOCATE THE #8 (CONDENSER TO DISCHARGE SIDE OF COMPRESSOR) HARDLINE. (SEE FIGURE 20, PAGE 12) LUBRICATE THE O-RING (SEE FIGURE 4, PG. 5) AND ATTACH TO THE TOP CONDENSER FITTING. (SEE FIGURE 7.) ATTACH HARDLINE TO THE FRAME USING AN ADEL CLAMP AND SHEET METAL SCREW IN THE POSITION SHOWN IN FIGURE 20, PAGE 12.
- LOCATE #6 (CONDENSER TO DRIER) HARDLINE AND TWO (2) #6 O-RINGS. LUBRICATE AND INSTALL O-RINGS (SEE FIGURE 4, PAGE 5) ON THE LINE AND ATTACH TO THE LOWER CONDENSER FITTING AND INLET FITTING ON THE DRIER. SEE FIGURE 7, THIS PAGE, AND FIGURE 20, PAGE 12. TIGHTEN USING TWO WRENCHES. (SEE FIGURE 5, ABOVE.)
- MOUNT DRIER ON PASSENGER SIDE INNER FENDER-WELL. (SEE FIGURE 20, PAGE 12.) LOCATE THE DRIER BY USING THE O.E.M. DIMPLES AND THE #6 LIQUID LINE FOR EXACT LOCATION. HOLES MAY PRE-EXIST, IF SO, MOUNT DRIER USING 1/4"-20X1" BOLT, TWO WASHERS ONE ON EACH SIDE OF INNER FENDER AND HEX NUT. IF HOLES DO NOT PRE-EXIST, DRILL A 1/4" HOLE IN THE O.E.M. DIMPLE ON FENDER-WELL TO MOUNT THE DRIER. AFTER MOUNTING DRIER, REMOVE PLUG FROM TOP OF DRIER AND INSTALL BINARY SAFETY SWITCH (INCLUDED IN CONDENSER KIT). SEE FIGURE 20 PAGE 12.
NOTE: BE SURE TO CHECK FLOW ARROW OF DRIER.

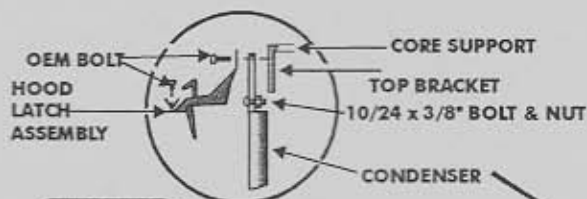

FIGURE 6
SIDE VIEW

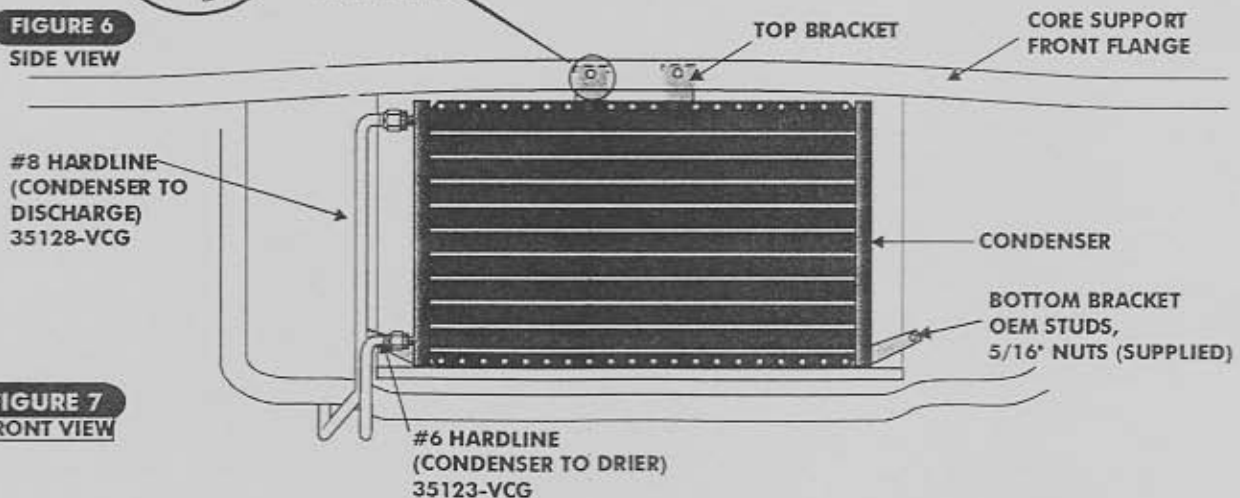

FIGURE 7
FRONT VIEW

CENTER VENT ASSEMBLY

NOTE O.E.M DASH SPEAKER ASSEMBLY MUST BE REMOVED SIMULTANEOUSLY WITH CENTER VENT ASSEMBLY. DASH SPEAKER IS MOUNTED WITH A BRACKET SCREWED ON TO COWL. REMOVE THIS SCREW AND PULL DOWN THE SPEAKER BRACKET TO DISENGAGE THE LOCATING TAB. THE WHOLE ASSEMBLY WILL COME OUT (SPEAKER AND VENT) BY SLIDING IT TOWARDS THE PASSENGER SIDE AND DOWN.

- REMOVE O.E.M. CENTER VENT ASSEMBLY, THE MOUNTING SCREWS ARE ON UNDERSIDE OF DASH, BELOW OUTLET
- DISASSEMBLE O.E.M. PLASTIC CENTER VENT PLENUM FROM THE METAL CENTER VENT OUTLET.
- ATTACH VINTAGE AIR CENTER VENT PLENUM TO O.E.M. METAL CENTER VENT OUTLET USING O.E.M. SCREWS.

NOTE HOLES WILL NEED TO BE DRILLED IN VINTAGE AIR CENTER VENT PLENUM TO MATCH EXISTING HOLES ON O.E.M. CENTER VENT

- REINSTALL MODIFIED CENTER VENT IN ITS ORIGINAL LOCATION USING O.E.M. FASTENERS
- REINSTALL SPEAKER (OPTIONAL)
- CUT TWO 15" LONG SECTIONS OF 2" DUCT HOSE AND INSTALL ONE TO EACH OF THE CENTER VENT HOSE ADAPTER

NOTE DUCT HOSE IS MEASURED WHEN STRETCHED

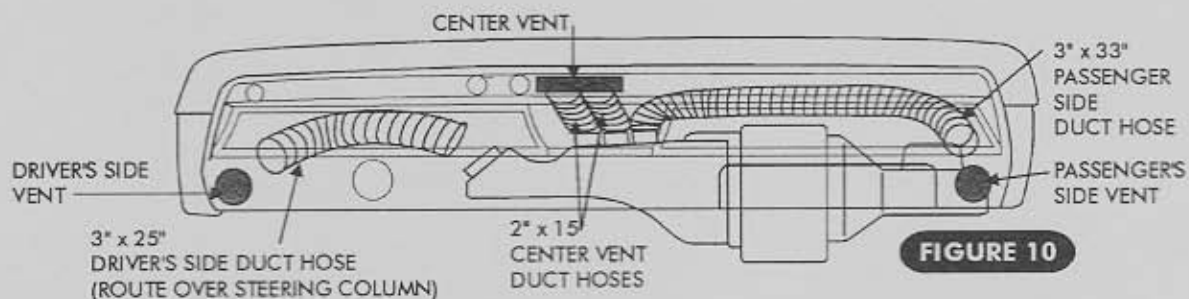

FIGURE 10

DEFROST & A/C VENT INSTALLATION DEFROST OUTLETS

NOTE TO EASE DRILLING OF DRIVER SIDE DEFROST MOUNTING HOLES, REMOVAL OF DASH INSTRUMENT PANEL IS OPTIONAL.

- LOCATE THE TWO (SUPPLIED) DEFROST VENTS. CENTER THE DEFROST VENTS UNDER THE DEFROST OUTLET GRILLE OF THE DASH, MARK AND DRILL OUT HOLES WITH A 1/8" DRILL BIT AND ATTACH DEFROST VENTS WITH ONE #8 x 1/2" SCREW (SEE FIGURES 8 & 9) INTO THE COWL.
- (PUT A SMALL AMOUNT OF SILICONE SEALER ON THE SCREW BEFORE TIGHTENING COMPLETELY).**
- INSTALL A 15" SECTION OF 2" DIAMETER DUCT HOSE ON EACH OF DEFROST VENTS.

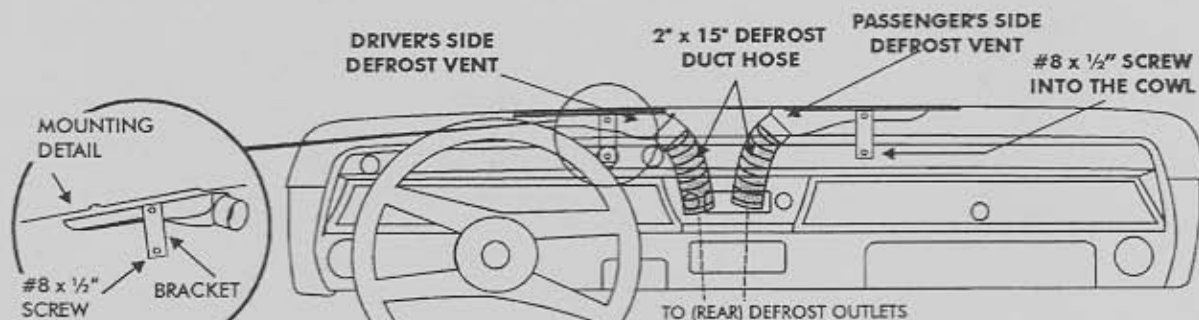

FIGURE 8

VIEW FROM BELOW
AND BEHIND DASH

FIGURE 9

CONTROL PANEL CONVERSION:

- REMOVE O.E.M. CONTROL CABLES. DISCARD CABLES BUT RETAIN O.E.M. SCREWS.
- REMOVE O.E.M. BLOWER SWITCH (DISCARD).
- LOCATE THE NEW BLOWER SWITCH TEMPLATE BELOW. USING THIS TEMPLATE, MARK LOCATIONS FOR THE NEW BLOWER SWITCH MOUNTING HOLES.
- DRILL THESE HOLES TO 1/8".
- INSTALL THE NEW BLOWER SWITCH USING O.E.M. SCREWS..
- REMOVE THE FACE PLATE COVERS FROM THE CONTROL PANEL. THERE IS A CLEAR COVER PLATE, AND A BLACK FACE PLATE. YOU MUST FILE THE BLOWER CONTROL LEVER OPENING OF THE BLACK FACE PLATE TO THE SAME DIMENSIONS AS THE CLEAR COVER PLATE TO ALLOW FULL TRAVEL OF NEW BLOWER CONTROL SWITCH LEVER. SEE FIGURE 13 BELOW.

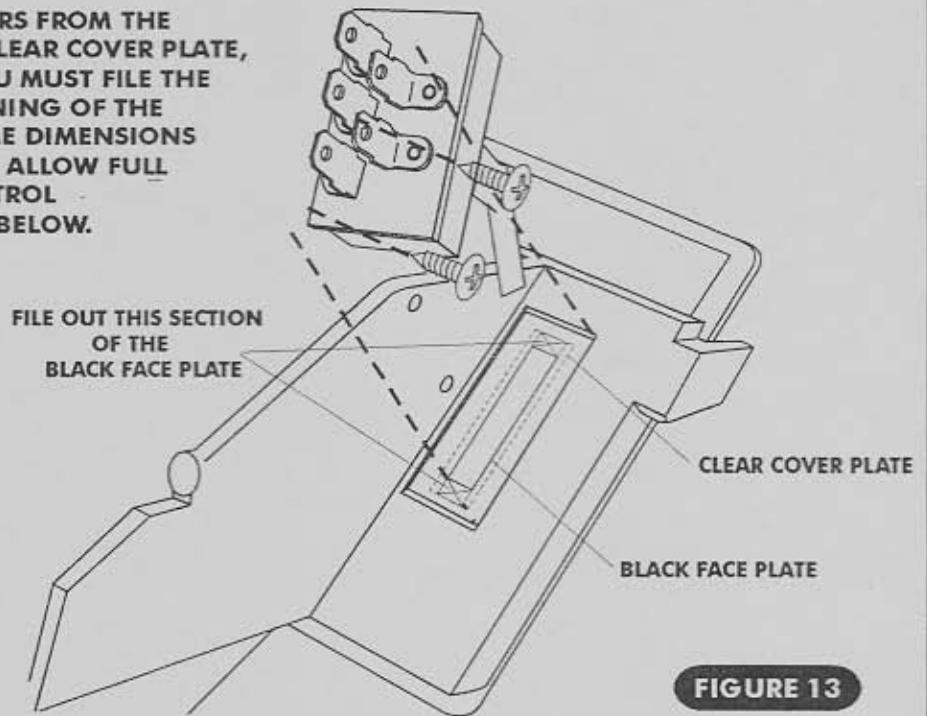
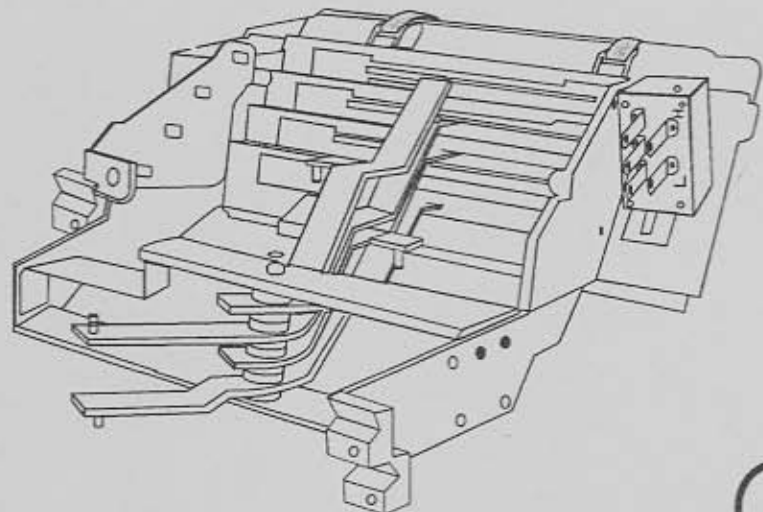
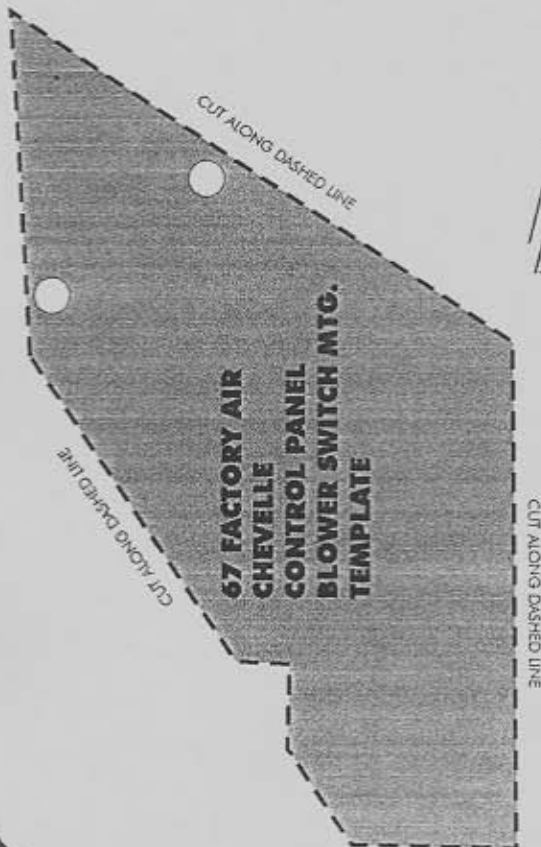

FIGURE 13



INSTALLATION CONTROL CABLE

- CONNECT ALL CABLES AS SHOWN IN FIGURE 14.
- ROUTE ALL CABLES AS SHOWN IN FIGURE 14.

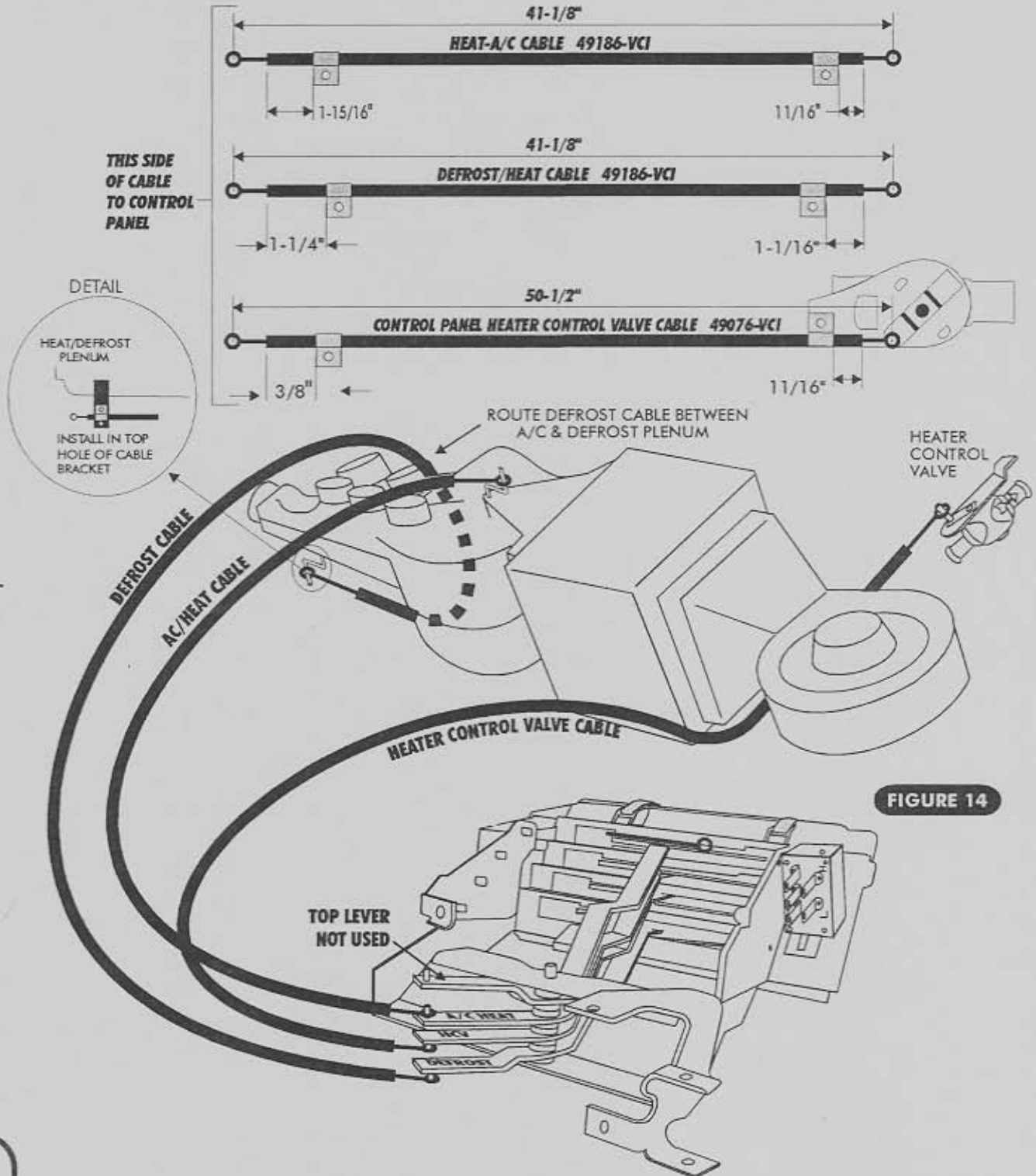

FIGURE 14

ELECTRICAL WIRING

- * IMPORTANT * VINTAGE AIR RECOMMENDS TESTING OF CONTROL PANEL & EVAPORATOR ON THE WORKBENCH FOR PROPER OPERATION, PRIOR TO INSTALLATION.

NOTE → THE COMPRESSOR SAFETY SWITCH (BOTH BINARY AND TRINARY TYPE) WILL NOT OPERATE COMPRESSOR CLUTCH, (SWITCH ON) UNTIL THERE IS REFRIGERANT PRESSURE AVAILABLE. CHECK FOR PROPER A/C COMPRESSOR CLUTCH POWER (12 VOLTS) AT THE THERMOSTAT. (THE OPTIONAL TRINARY SWITCH CONTROLS AN ELECTRICAL FAN. SEE INSTRUCTIONS PACKAGED WITH THE SWITCH)

NOTE → ALL VINTAGE AIR MICRO SWITCHES ARE CAREFULLY SET AT THE FACTORY. HOWEVER... IF YOU SHOULD EXPERIENCE A PROBLEM WITH THE OPERATION OF YOUR A/C UNIT - DOUBLE CHECK THE ADJUSTMENT OF THE MICRO SWITCHES.

MICRO SWITCH ADJUSTMENTS

NORMAL POSITION

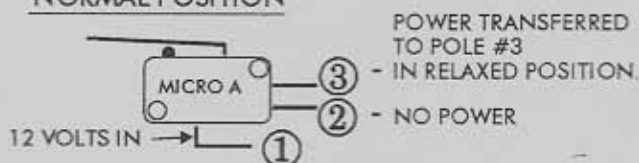

DEPRESSED POSITION

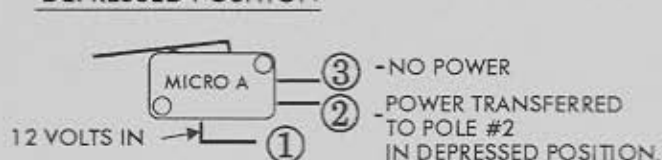

BY DEPRESSING THE ARM ON THE MICRO SWITCH AN AUDIBLE CLICK WILL BE HEARD TRANSFERRING POWER TO POLE #2.
RELEASE THE ARM AND ANOTHER CLICK WILL BE HEARD, TRANSFERRING POWER TO POLE #3.

- CONNECT ALL CABLES AS SHOWN IN FIGURE 14, PAGE 8.
- AFTER INSTALLING CABLES AND VERIFYING FULL OPENING AND CLOSING OF EVAPORATOR DOOR, HEAT/DEFROST DOOR AND HEATER CONTROL VALVE, YOU ARE READY TO COMPLETE THE WIRING TO VERIFY PROPER OPERATION OF THE UNIT.**

WIRING FOR TESTING

- CONNECT WIRING FROM EVAPORATOR UNIT TO SWITCHES. REFER TO WIRING DIAGRAM ON PAGE 16.
- ATTACH ALL WHITE WIRES TOGETHER AND GROUND TEMPORARILY.
- THE RED WIRE IN THE WIRING HARNESS CONNECTS TO BATTERY POWER. (12 VOLTS)
- THE PURPLE WIRE WILL ALSO NEED TO BE CONNECTED TO DIRECT POWER FOR TESTING PURPOSES. *IT MUST BE HOOKED TO IGNITION ON POWER ONLY ONCE INSTALLED IN THE VEHICLE.*
- CONNECT HEATER CONTROL VALVE CABLE TO THE COLD/HOT LEVER ON THE CONTROL PANEL. ADJUST THE CABLE ON THE VALVE AND TIGHTEN THE CLAMP.
- ADJUST THE CONTROL PANEL LEVERS TO THE **A/C MODE**. SEE PG.14. VERIFY THAT THE HEATER CONTROL VALVE IS CLOSED.
- TURN THE BLOWER SPEED SWITCH TO **LOW**. THERE SHOULD BE POWER AT THE A/C THERMOSTAT.
- ADJUST THE CONTROL PANEL TO THE **DEFROST MODE**. YOU SHOULD HAVE POWER AT THE A/C THERMOSTAT.
- ADJUST THE CONTROL PANEL LEVERS TO THE **HEAT MODE**. YOU SHOULD NOT HAVE POWER AT THE THERMOSTAT IN THE HEAT MODE.
- AFTER CONFIRMING PROPER SYSTEM OPERATION, **TAG AND LABEL** THE WIRES FOR EASE OF INSTALLATION INTO THE VEHICLE.
- REMOVE CABLES FROM THE EVAPORATOR AND CONTROL PANEL.

EVAPORATOR INSTALLATION

IMPORTANT: BEFORE PROCEEDING WITH THE INSTALLATION OF THE EVAPORATOR, BE SURE THAT ALL WIRING AND CABLES HAVE BEEN CHECKED FOR PROPER OPERATION, BY FOLLOWING PAGES 8 & 9.

- LAY EVAPORATOR AND CONTROL PANEL UNDER DASH SIDE-BY-SIDE (SEE FIGURE 17 PAGE 11).
- ROUTE AND ATTACH ALL CABLES FROM CONTROL PANEL TO EVAPORATOR AS SEEN IN FIGURE 17 PAGE 11 AND FIGURE 14, PAGE 8.
- RAISE EVAPORATOR UP, ALIGN BRACKET WITH FIREWALL BOLT HOLE #1 AND MOUNT WITH 1/4"-20X1" BOLT AND WASHER. (SEE FIGURE 12 PAGE 6) LEVEL EVAPORATOR UNDER DASH, AND ALIGN BLOWER BRACKET WITH DASH. DRILL 1/8" HOLES, THEN ATTACH BRACKET TO THE DASH WITH 2 #8 X 1/2" SCREWS.
- ATTACH THE LONG A/C PLENUM BRACKET TO THE O.E.M. DEFROST DUCT MOUNTING HOLE IN THE COWL WITH O.E.M. SCREW.
- DRILL A 1/8" HOLE IN FIREWALL USING DEFROST PLENUM BRACKET FOR HOLE LOCATION AND USE A #8 X 1/2" SCREW AND TIGHTEN BRACKET TO FIREWALL.
- DRILL A 9/16" HOLE 1" BELOW EVAPORATOR IN LINE WITH THE DRAIN, ATTACH DRAIN HOSE TO THE EVAPORATOR AND ROUTE THRU THE 9/16" HOLE. INSTALL THE 90° FITTING AND 4" DRAIN HOSE. CUT AND ORIENT HOSE AS SHOWN IN FIGURE 18, PAGE 11.

NOTE FOR MAXIMUM AIR FLOW, DUCT HOSE MUST BE PULLED TIGHT BETWEEN EVAPORATOR AND VENTS.

- ATTACH ALL DUCT HOSE TO CORRESPONDING DUCTS.
- INSTALL RADIO
- INSTALL CONTROL PANEL

HEATER HOSE INSTALLATION

NOTE HEATER HOSE IS NOT SUPPLIED IN THIS KIT. VINTAGE AIR RECOMMENDS ABOUT 7 FT. OF HIGH QUALITY 5/8" AUTOMOTIVE HEATER HOSE AVAILABLE AT MOST AUTOMOTIVE PARTS RETAILERS.

- INSTALL 3/8" O.D. GROMMET IN FIREWALL
- ROUTE HEATER CONTROL VALVE CABLE (LONGEST CABLE OF THE THREE) THROUGH THE 3/8" OPENING ON THE FIRE WALL COVER.
- ATTACH HEATER CONTROL VALVE TO CABLE, ORIENTED AS SHOWN IN FIGURE 20, PAGE 12. CUT AND INSTALL USING HOSE CLAMPS, A 14" LONG SECTION OF HEATER HOSE BETWEEN THE HEATER CONTROL VALVE AND THE A/C UNIT AS SHOWN IN FIGURE 20, PAGE 12.
- CUT ANOTHER 25" LONG SECTION OF HEATER HOSE, INSTALL USING HOSE CLAMPS BETWEEN THE HEATER CONTROL VALVE AND THE INTAKE MANIFOLD COOLANT PORT AS ILLUSTRATED IN FIGURE 20, PAGE 12.
- LASTLY, USE THE REMAINING HEATER HOSE (ABOUT 45") TO CONNECT THE A/C UNIT TO THE WATER PUMP SUCTION PORT, AS PICTURED IN FIGURE 20, PAGE 12.

NOTE HEATER CONTROL VALVES ARE DIRECTIONAL, AND WILL LEAK HOT WATER INTO THE HEATER IF INSTALLED BACKWARDS. VALVE MUST BE INSTALLED WITH ARROW POINTING TOWARDS THE EVAPORATOR AND MUST BE INSTALLED IN THE HOSE CONNECTED TO THE INTAKE MANIFOLD (PRESSURE) HOSE. SYSTEMS WHICH DO NOT COOL ARE OFTEN THE RESULT OF IMPROPERLY INSTALLED OR ADJUSTED HEATER CONTROL VALVES.

A/C HOSE INSTALLATION

- LOCATE THE #6 HARDLINE (DRIER TO EXPANSION VALVE) AND TWO (2) #6 O'RINGS. (SEE FIGURE 20, PAGE 12)
- LUBRICATE O'RINGS (SEE FIGURE 4, PG. 4). PASS 90° FITTING THROUGH FIREWALL COVER AND CONNECT TO EXPANSION VALVE. CONNECT THE OTHER END TO DRIER AS SHOWN IN FIGURE 20, PAGE 12.

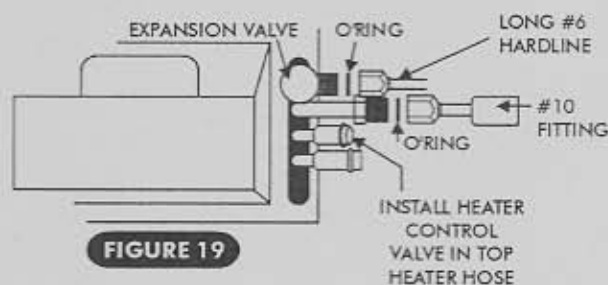
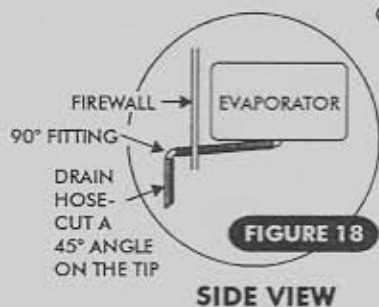
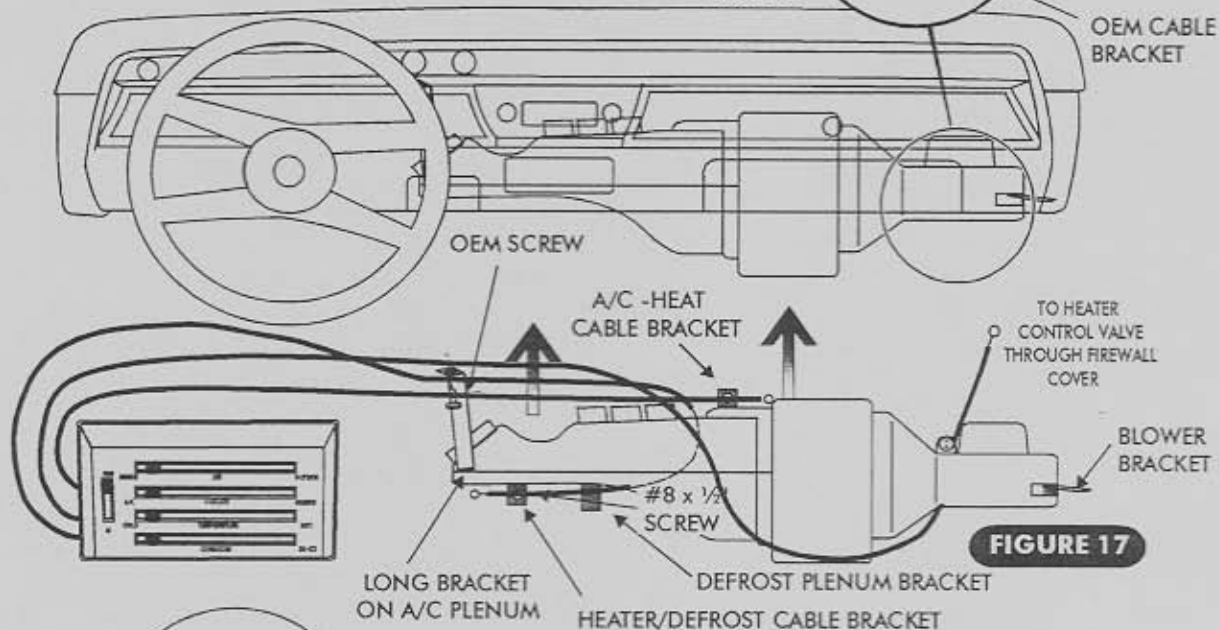
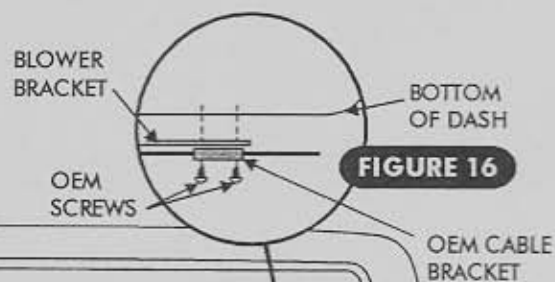
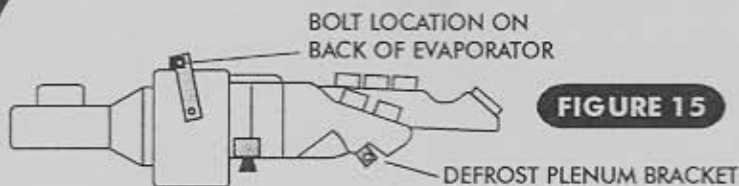

A/C HOSE INSTALLATION (CONTINUED)

- DRILL 1/8" HOLES FOR ADEL CLAMPS IN POSITION NOTED IN FIGURE 20, PAGE 12, AND INSTALL ADEL CLAMPS USING SUPPLIED #8 x 1/2" SCREWS TO SUPPORT REFRIGERANT HOSES AND HARNESS.
- LOCATE THE #8 DISCHARGE HOSE AND TWO (2) #8 O'RINGS. LUBRICATE O'RINGS (SEE FIGURE 4, PAGE 4), THEN CONNECT THE 135° FITTING TO THE COMPRESSOR'S DISCHARGE PORT AND THE OTHER END TO THE #8 HARDLINE ATTACHED TO THE FRAME, AND TIGHTEN USING TWO (2) WRENCHES (SEE FIGURE 5, PAGE 5).
- LOCATE THE #10 SUCTION HOSE AND TWO (2) O'RINGS. LUBRICATE O'RINGS AND THREADS (SEE FIGURE 4, PG. 5). PUSH STRAIGHT END THRU FIREWALL COVER OPENING FROM ENGINE SIDE (SEE FIGURE 12, PAGE 4) AND ATTACH TO THE SUCTION FITTING ON EVAPORATOR (SEE FIGURE 19, ABOVE). INSTALL 90° END TO SUCTION PORT ON COMPRESSOR. (SEE FIGURE 20, PAGE 12.)
- WRAP THE METAL FITTINGS OF THE #10 SUCTION LINE AND #6 LIQUID LINE AT THE EVAPORATOR AND EXPANSION VALVE WITH PRESS TAPE TO PREVENT CONDENSATION DRIPS INSIDE THE VEHICLE (SEE FIGURE 19, PAGE 11).
- INSTALL COMPRESSOR SAFETY SWITCH (BINARY TYPE) ON DRIER, BEING CAREFUL NOT TO OVER TIGHTEN. (SEE FIGURE 20, PAGE 12).

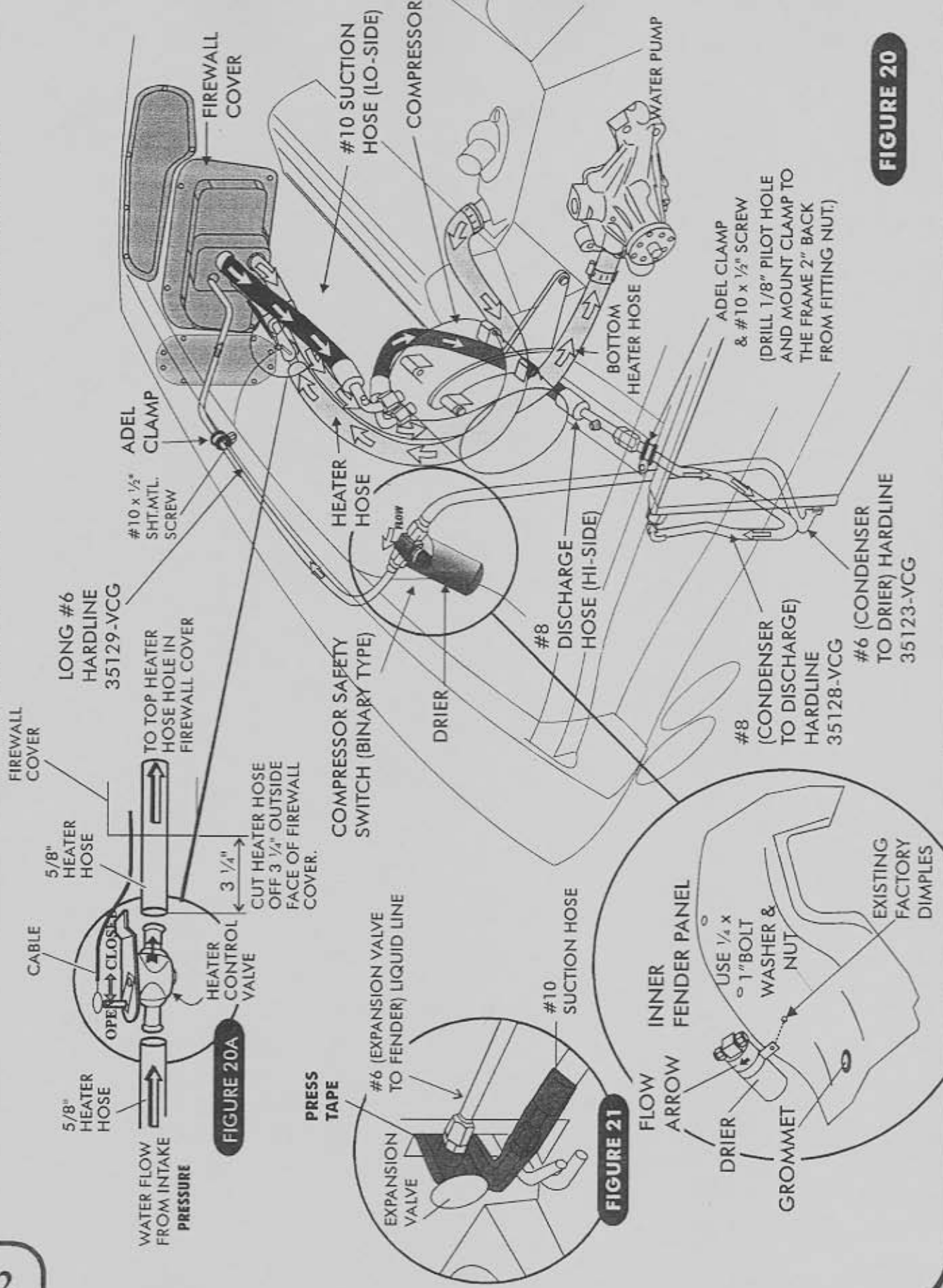
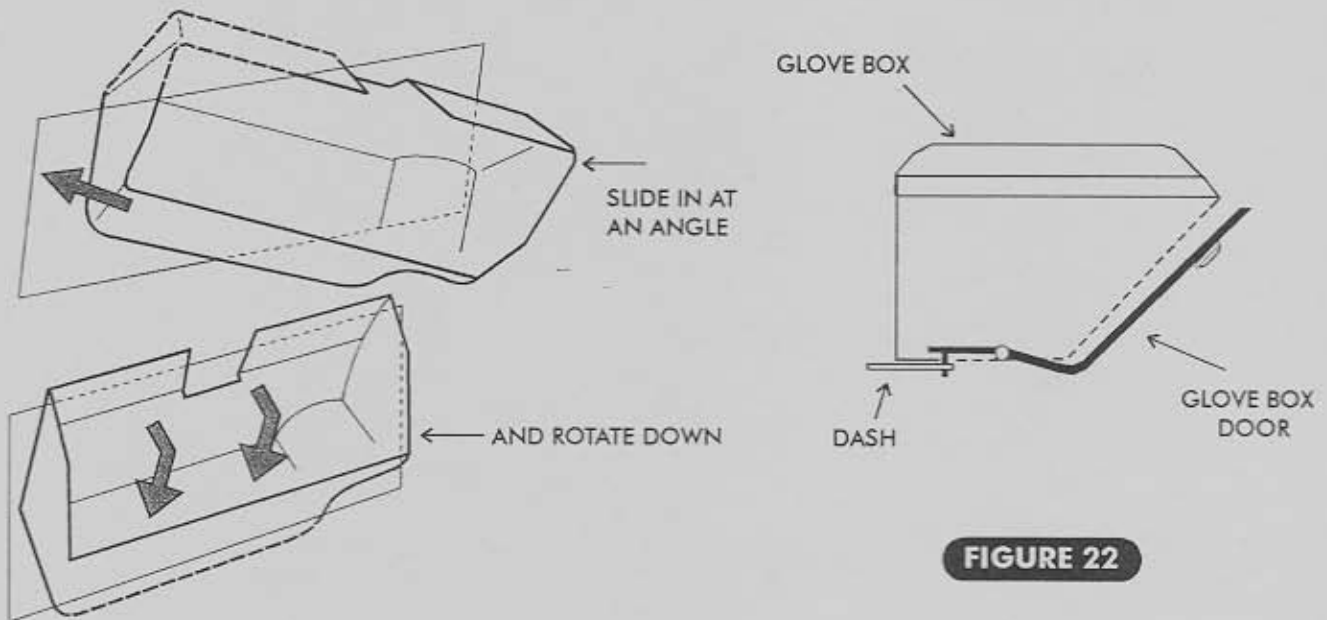

FIGURE 20

FIGURE 21

FINAL STEPS

- ASSEMBLE NEW GLOVE BOX WITH FIVE (5) SUPPLIED S-CLIPS. INSTALL AS SHOWN IN FIGURE 22.
- ALIGN GLOVE BOX IN DASH AND SECURE WITH 2 EACH #8 PAN-HEAD SHEET METAL SCREWS ON EACH SIDE.
- INSTALL GLOVE BOX DOOR STUDS THROUGH THE DASH. SECURE THE GLOVE BOX DOOR TO THE DASH USING O.E.M. FASTENERS. SEE FIGURE 22.

FIGURE 22

- RE INSTALL PASSENGER SIDE KICK PANEL. (NOTE: YOU MAY NEED TO TRIM 1/2"-3/4" OFF THE TOP CORNER OF THE KICK PANEL TO CLEAR THE BLOWER.)
- RE INSTALL ANY PREVIOUSLY REMOVED COMPONENTS (BATTERY BOX, BATTERY, GLOVE BOX DOOR, RADIO AND DASHBOARD).
- FILL RADIATOR WITH AT LEAST A 50/50 MIXTURE OF APPROVED ANTIFREEZE AND WATER. IT IS THE OWNERS RESPONSIBILITY TO KEEP THE FREEZE PROTECTION AT THE PROPER LEVEL.

FAILURE TO FOLLOW ANTIFREEZE RECOMMENDATIONS WILL CAUSE HEATER CORE TO CORRODE PREMATURELY AND POSSIBLY BURST IN A/C MODE AND/OR FREEZING WEATHER, VOIDING YOUR WARRANTY.

- CHECK COMPLETE A/C ASSEMBLY FOR PROPER OPERATION.

***IMPORTANT NOTE:**

- PRIOR TO OPERATING A/C SYSTEM, START ENGINE AND RUN UNTIL NORMAL TEMPERATURE IS REACHED. PLACE LEVER IN HEAT POSITION AND OPERATE FAN (BLOWER). SYSTEM WILL NOW HEAT VEHICLE. BE SURE ENGINE THERMOSTAT HAS OPENED AND THE APPROVED ANTI-FREEZE MIXTURE HAS BEEN CIRCULATED THROUGH THE HEATER CORE.
- VINTAGE AIR RECOMMENDS THAT ALL A/C SYSTEMS BE SERVICED BY A CERTIFIED AUTOMOTIVE AIR CONDITIONING TECHNICIAN ONLY. SEE INSIDE COVER FOR SERVICE INFORMATION.

OPERATION OF CONTROLS

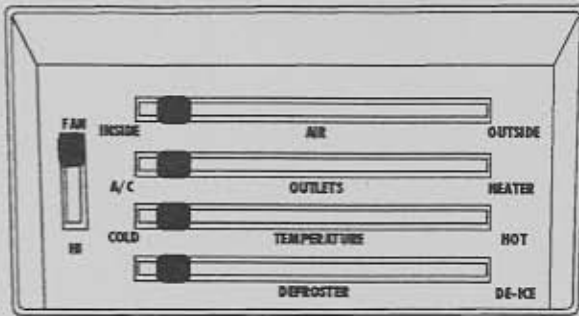

OFF

- ALL HORIZONTAL SLIDE LEVERS ARE TO THE LEFT, AND FAN SPEED SWITCH IS ALL THE WAY TO THE TOP.

NOTE: THIS SYSTEM DOES NOT USE AIR LEVER

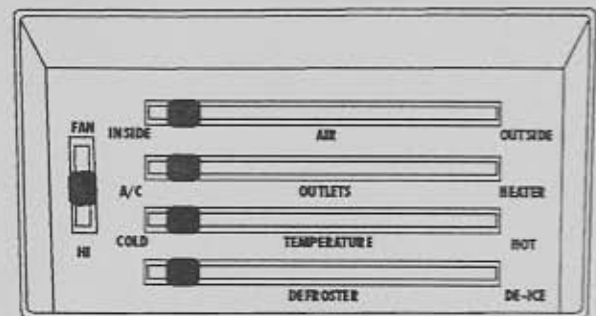

A/C MODE

- ALL HORIZONTAL SLIDE LEVERS ARE TO THE LEFT, AND DESIRED FAN SPEED IS SELECTED.

NOTE: A/C DUCT TEMPERATURE MAY BE RAISED BY MOVING TEMPERATURE LEVER SLIGHTLY TO THE RIGHT.

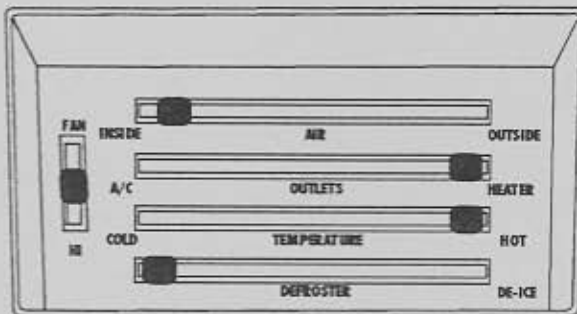

HEAT MODE

- SELECT DESIRED FAN SPEED.
 - SLIDE OUTLETS LEVER TO HEATER POSITION.
- NOTE: TEMPERATURE LEVEL CAN BE VARIED BY ADJUSTING LEVER.**
- SLIDE TEMPERATURE LEVER TO HOT POSITION.
 - SLIDE DEFROSTER LEVER TO DE-ICE POSITION.

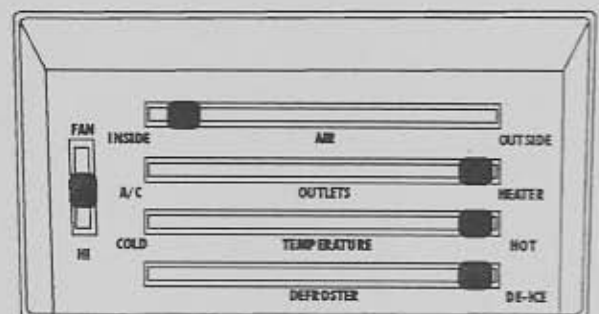

DEFROST MODE

- SELECT DESIRED FAN SPEED.
 - SLIDE OUTLETS LEVER TO HEATER POSITION
- NOTE: TEMPERATURE LEVEL CAN BE VARIED BY ADJUSTING LEVER.**
- SLIDE TEMPERATURE LEVER TO HOT POSITION.
 - SLIDE DEFROSTER LEVER TO DE-ICE POSITION.

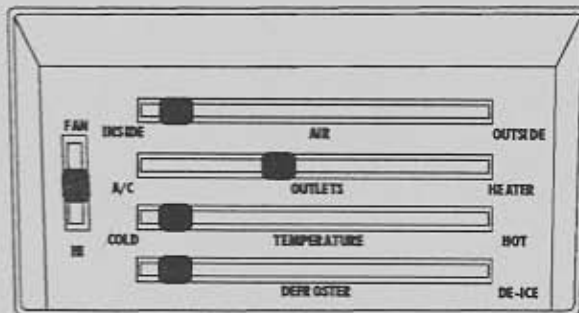

BI-LEVEL A/C MODE

- SELECT DESIRED FAN SPEED.
- SLIDE OUTLETS LEVER TO JUST LEFT OF CENTER.
- SLIDE TEMPERATURE LEVER TO COLD POSITION.
- SLIDE DEFROSTER LEVER ALL THE WAY TO THE LEFT.

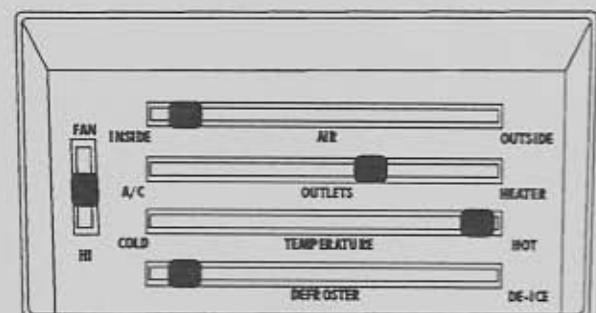

BI-LEVEL HEAT MODE

- SELECT DESIRED FAN SPEED.
- SLIDE OUTLETS LEVER TO HEATER POSITION.
- SLIDE TEMPERATURE LEVER TO JUST RIGHT OF CENTER.
- SLIDE DEFROSTER LEVER ALL THE WAY TO THE LEFT.

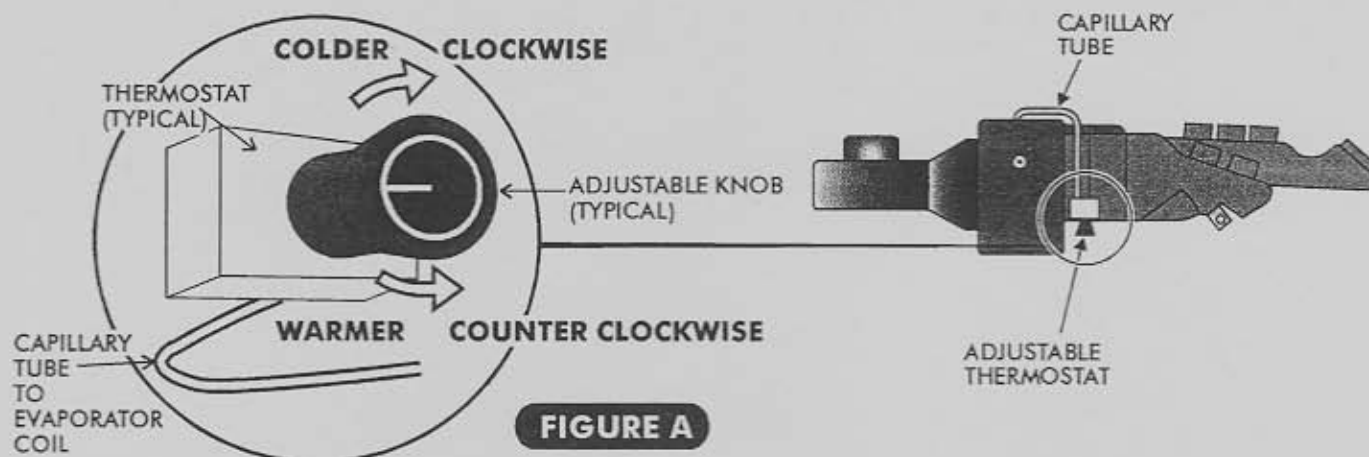
FIGURE A

AIR CONDITIONING ADJUSTMENTS:

- THE AIR CONDITIONER THERMOSTAT CONTROLS COIL TEMPERATURE. IT IS SHIPPED ADJUSTED FULLY COLD (CLOCKWISE), IN THE MAJORITY OF CASES THE A/C WILL OPERATE CORRECTLY AS SHIPPED.
- TURNING THE KNOB ON THE THERMOSTAT CLOCKWISE MAKES THE SYSTEM OPERATE COLDER. IF THE THERMOSTAT IS SET TOO COLD THE EVAPORATOR MAY "ICE UP" IN HUMID CLIMATES - THE EVAPORATOR COIL IS RESTRICTED WITH ICE AND COLD AIR FLOW WILL BE REDUCED.
- TURNING THE KNOB COUNTER CLOCKWISE MAKES THE SYSTEM OPERATE WARMER. THE COMPRESSOR CLUTCH WILL CYCLE OFF MORE FREQUENTLY AND THE A/C SYSTEM WILL NOT GET AS COOL AS IT COULD.

ADJUSTING A/C THERMOSTAT

1.) **SYMPTOM:** THE A/C WORKS WELL AT FIRST THEN QUITS COOLING. THE AIR FLOW FROM THE VENTS IS LOW AND THE COMPRESSOR CYCLES INFREQUENTLY.

SOLUTION: THE THERMOSTAT IS SET TOO COLD AND THE EVAPORATOR IS "ICING UP" AND RESTRICTING AIR FLOW. ALLOW THE ICE TO MELT AND SET THE THERMOSTAT WARMER (COUNTER CLOCKWISE) 10% OF A TURN EACH ADJUSTMENT UNTIL THE SYMPTOMS DIMINISH.

2.) **SYMPTOM:** A/C NEVER GETS COLD AND THE COMPRESSOR CLUTCH CYCLES FREQUENTLY.

SOLUTION: THE THERMOSTAT IS SET TOO WARM. SET THE THERMOSTAT COLDER (CLOCKWISE) 10% OF A TURN EACH ADJUSTMENT UNTIL THE COMPRESSOR CLUTCH CYCLES INFREQUENTLY. AVOID SETTING THE THERMOSTAT TOO COLD.

3.) **SYMPTOM:** THE A/C NEVER GETS COLD, SOMETIMES EVEN BLOWS HOT, AND THE A/C COMPRESSOR CLUTCH INFREQUENTLY CYCLES OFF.

SOLUTION: THE HEATER MAY BE ON AT ALL TIMES. CAREFULLY FEEL AROUND THE HEATER HOSES AT THE FIREWALL. THEY SHOULD NOT BE WARM WHEN THE A/C IS ON. IF THE HOSES ARE HOT...

A) - THE HEATER CONTROL VALVE MAY BE INSTALLED BACKWARDS. CHECK THE FLOW DIRECTION ARROW ON THE VALVE AGAINST THE ILLUSTRATION IN YOUR INSTALLATION INSTRUCTIONS.

B) - CABLE OPERATED: THE VALVE MAY BE MISADJUSTED. CONFIRM VALVE IS COMPLETELY SHUTTING OFF HOT WATER.

C) - HEATER CONTROL VALVE IS INSTALLED IN WRONG HEATER HOSE.

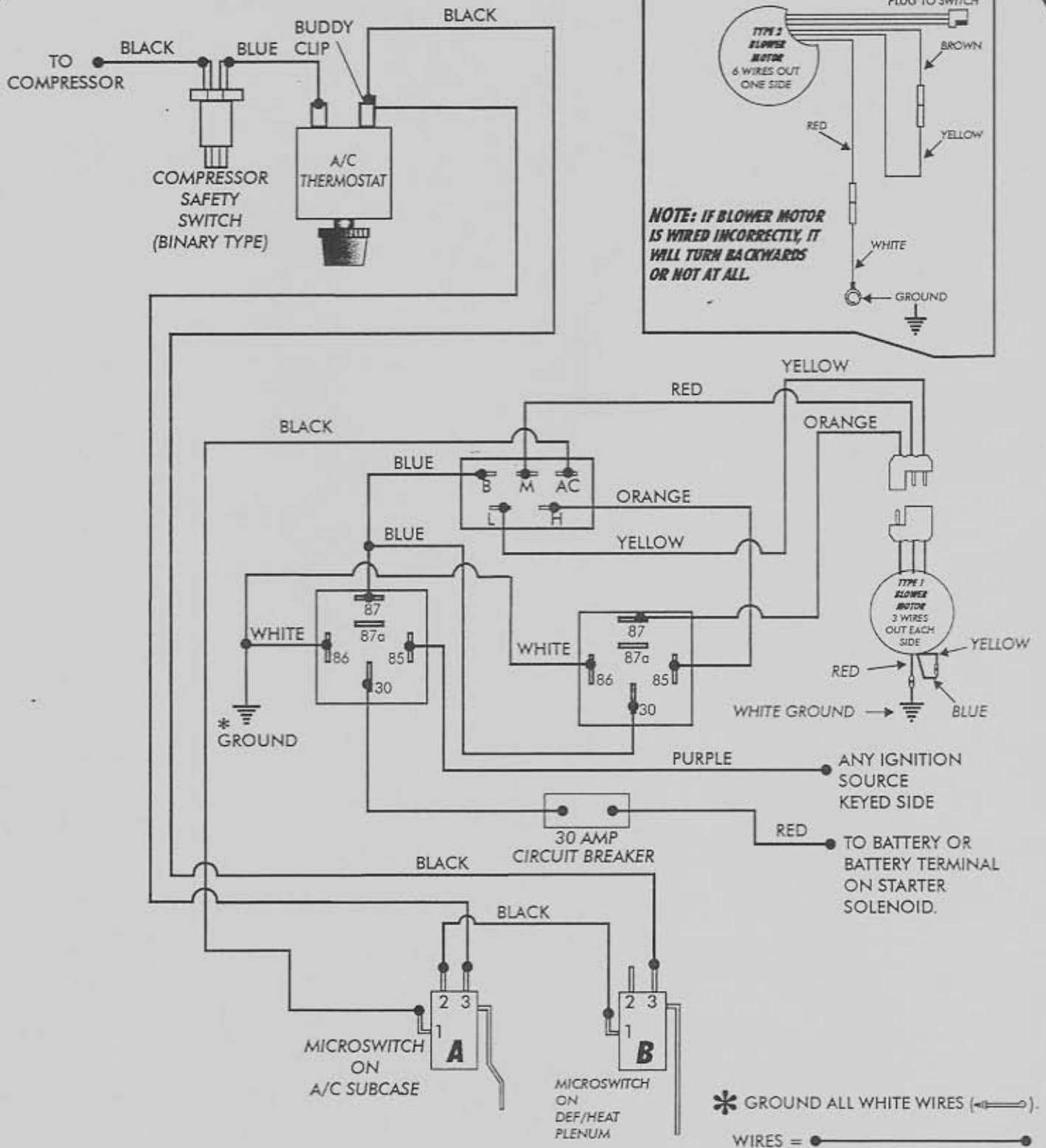

63367-ACA
INSTALLATION KIT PARTS LIST

No.	QYT.	PART #	DESCRIPTION
1.	11	18125-VUB	.25 I.D. x .750 O.D. FLAT WASHER ZINC
2.	5	18136-VUB	1/4"-20 HEX NUT
3.	6	18290-VUB	1/4"-20 x 1" HEX BOLT
4.	13"	31050-VUD	1/2" DRAIN HOSE (PER INCH)
5.	20"	49003-VUP	PRESS TAPE (PER INCH)
6.	1	65598-VUE	1/2" DRAIN ELBOW

46465-ACA
CABLE KIT PARTS LIST

No.	QYT.	PART #	DESCRIPTION
1.	5	18056-VUB	CABLE CLIP
2.	1	33138-VUI	1/4" RUBBER GROMMET
3.	1	46104-VUH	HEATER CONTROL VALVE (PULL CLOSE)
4.	1	49076-VCI	CABLE LEVER 50-1/2" x 47-7/8"
5.	2	49186-VUI	LEVER CABLE 41-1/8" x 37"
6.	6	65975-VUE	1/8" PUSH ON RING



ACCESSORY KIT PACKING LIST

ACCESSORY KIT 78166-ACF

No.	QTY.	PART No.	DESCRIPTION	
1.	5'	06200-VUE	2" DUCT HOSE	_____
2.	6'	06300-VUE	3" DUCT HOSE	_____
3.	1	47367-ACA	CONTROL PNL WIRING KIT	_____
4.	3	33137-VUI	GROMMET LARGE	_____
5.	1	46465-ACA	'67 CHEVELLE W/FA CABLE KIT	_____
6.	1	49267-VCI	'66-'67 CHEVELLE GLOVE BOX	_____
7.	1	49368-LHR	'67 CHEVELLE CENTER LOUVER ADAPTER	_____
8.	1	62137-VCE	'66-'67 EL CAMINO FIREWALL COVER	_____
9.	1	62180-VCI	'67 CHEVELLE FRESH-AIR COVER	_____
10.	1	62181-VCI	'67 CHEVELLE EVAPORATOR COVER	_____
11.	1	62182-VCI	'67 CHEVELLE KICK-PANEL COVER	_____
12.	1	63367-ACA	'67 CHEVELLE INSTALLATION KIT	_____
13.	1	63366-VCE	'67 CHEVELLE DEFROST KIT	_____

CHECKED BY: _____
 PACKED BY: _____
 DATE: _____

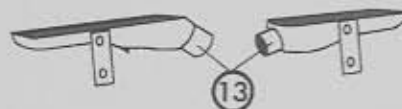
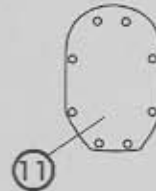
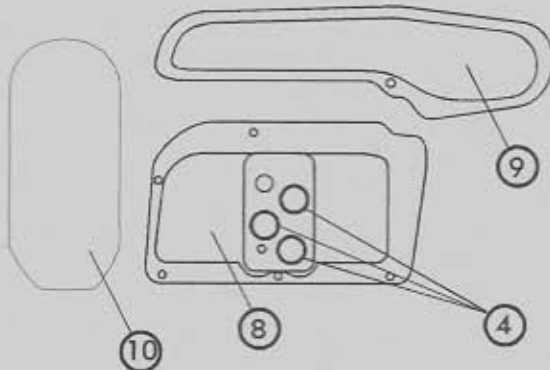
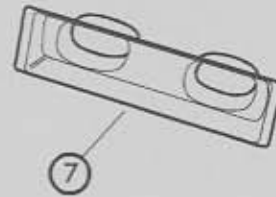
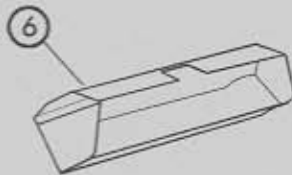
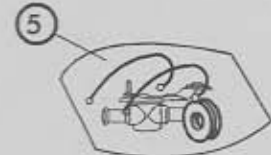
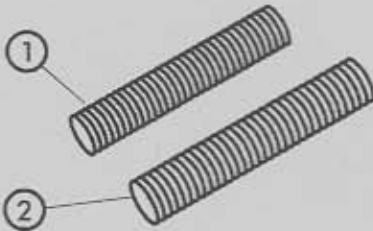

EVAPORATOR KIT PACKING LIST

EVAPORATOR KIT
56467-ACZ-A

	QTY.	PART No.	DESCRIPTION	
1.	1	76467-ACE-A	'66-'67 CHEVELLE W/FA EVAP. SUBCASE	_____
2.	1	78166-ACF	1967 CHEVELLE W/FA ACCESSORY KIT	_____

CHECKED BY: _____
 PACKED BY: _____
 DATE: _____

①

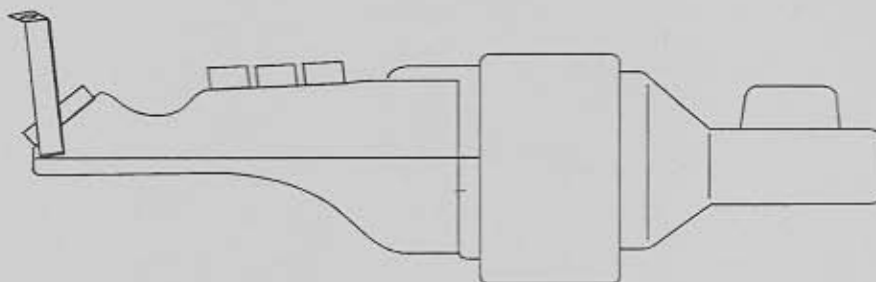

②

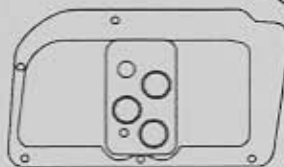
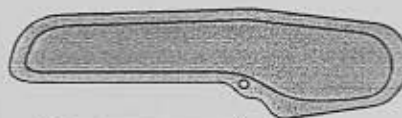
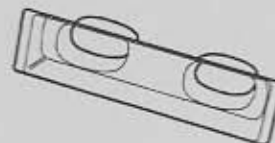
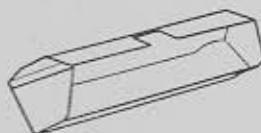
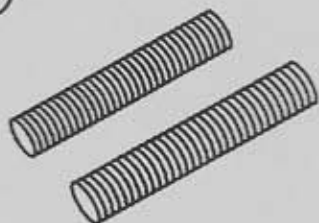

**ACCESSORY KIT
78166-ACF**